



PANEL SS450

DESCRIPTION

PRODUCT COVERED

This section of the procedure covers a steel roof panel which is identified as "Panel SS450." The panel is produced at the job sites by portable rolling machines. The panel is roll formed from No. 24 MSG minimum gauge coated steel to the configuration shown in ILL. 1. The panel may also have a paint over coating. The Report included in this Procedure, following this section, is to be examined for comparison with copies of the Report in stock. The Report issue date is October 1, 2002.

SPECIFICATION OF FINISHED PRODUCT

THICKNESS

The base metal thickness of the steel used in the fabrication of the panel shall be not less than .0225 in. (No. 23 MSG minimum gauge). This thickness shall not include the coating or any paint finish.

DIMENSIONS

The cross-section dimensions of the panel shall be in accordance with the cross-section shown in ILL. 1.

STRENGTH

The strength records of the steel shall be reviewed. The steel used shall conform to ASTM A653 Grade 50 specifications or the minimum yield point of the steel shall be 50,000 psi.

Listed Construction Numbers

#370

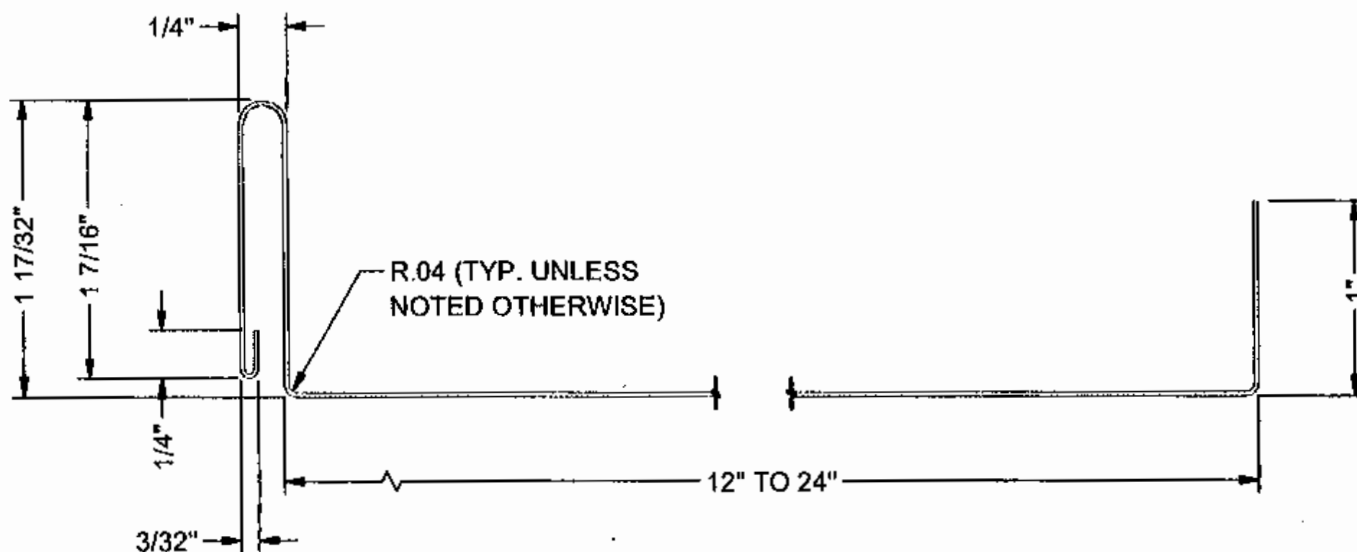
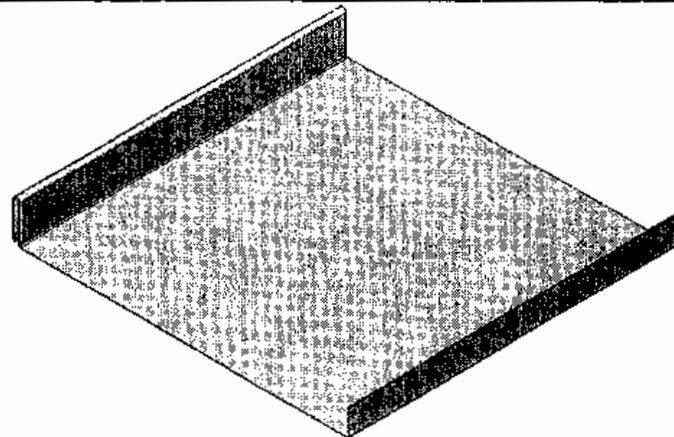

NOTE:
MATERIAL USAGE: 4"

MATERIAL		LENGTH	FINISH		NEW TECH MACHINERY CORP.				
REVISION HISTORY	REV	ECN NO.	DATE	RELEASED BY	TOLERANCES	DRAWN BY	PART NAME		
	0		7/2/02		.XX = ± .01	SAWYER	SS450 PANEL PROFILE		
					.XXX = ± .005	DATE			
					FRACTION = ± 1/32"	7/2/2002	CHECK BY	SIZE	SHEET
				ANGLE = ± 1/2'		DATE	SCALE	1 OF 1	0
							FULL	PART NUMBER	
								SS450	



333 Pfingsten Road
Northbrook, Illinois 60062-2096
United States Country Code (1)
(847) 272-8800
FAX No. (847) 272-8129
<http://www.ul.com>

September 13, 2002

New Tech Machinery
Mr. Gary Battistella
1300 40th
Denver, CO 80205-3311

Our Reference: R14692 / 02NK35153

Subject: Classification of Metal Roof Deck Panels

Dear Mr. Battistella:

Project 02NK35153 was opened under File R14692 to establish UL Classification for your "SS450", "SS150", "SS675" and "FF100" metal panels. It was determined that your "SS450", "SS150", "SS675" are equivalent to the Classified panels in Construction Nos. 370, 554 and 343 respectively. It was also determined that your "FF100" panel was not equivalent to the Classified panel in Construction No. 456.

Currently, we are processing the following:

1. Follow-Up Service Procedure R14692, Volume 4.
2. Revisions to your TJPV Classification Card.
3. Revisions to Roof Deck Construction Numbers 343, 370 and 554.

This will serve to terminate Project 02NK35153.

If you have any questions on the above, please feel free to contact us.

Very truly yours,

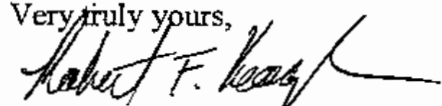
ROBERT F. KEOGH (Ext. 41510)
Project Engineer
Fire Protection Division

Reviewed by:

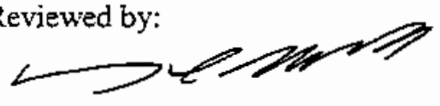
DOUGLAS C. MILLER (Ext. 43262)
Engineering Group Leader
Fire Protection Division

DESCRIPTION

PRODUCT COVERED:

This section of the Procedure covers coated steel roof panels which are identified by the manufacturer as "SS450".

The panels are roll-formed from No. 24 MSG minimum gauge coated steel to the configuration shown in ILL. 1. The panels may also have a paint finish over the coating.

SPECIFICATIONS OF FINISHED PRODUCT:

THICKNESS

The base metal thickness of the steel used in the fabrication of the panels shall be not less than 0.0225 in. (No. 24 MSG minimum gauge). This thickness shall not include the coating or any paint finish.

DIMENSIONS

The cross sectional dimensions of the finished panels shall be in accordance with the cross section shown in ILL. 1.

The panels are made in any convenient length.

STRENGTH

The strength records of the manufacturer of the steel shall be reviewed. The steel shall conform to ASTM A653 Grade 50 specifications or the minimum yield point shall be 50,000 psi.

CLASSIFICATION INFORMATION:

The following information shall be included on all Classification Markings pertaining to products described in this section:

As To Uplift Resistance Only
Class 90
As Shown By Construction No. 370

MARKING INFORMATION:

In addition, the following information shall appear either on the product or package or on the Classification Marking:

Classified Company's name
Product identification (type designation)
and
Factory identification (if applicable).

Northbrook, Illinois • (847) 272-8800
Melville, New York • (631) 271-6200
Santa Clara, California • (408) 985-2400
Research Triangle Park,
North Carolina • (919) 549-1400
Camas, Washington • (360) 817-5500



NEW TECH MACHINERY CORP

1300 40TH ST
DENVER CO 80205

RE: Project Number(s) - 02NK35153/R14692

Your most recent Certification is shown below. You may also view this information, or a portion of this information (depending on the product category), on UL's Online Certifications Directory at www.ul.com/database. Please review the text and contact the Conformity Assessment Services staff member who handled your project if revisions are required. For instructions on placing an order for this information in a 3 x 5-inch format, you may refer to the enclosed order form for UL Card Service.

TGKX
Roof Deck Constructions

October 1, 2002

Construction No. 370
Uplift - Class 90
Fire Not Investigated

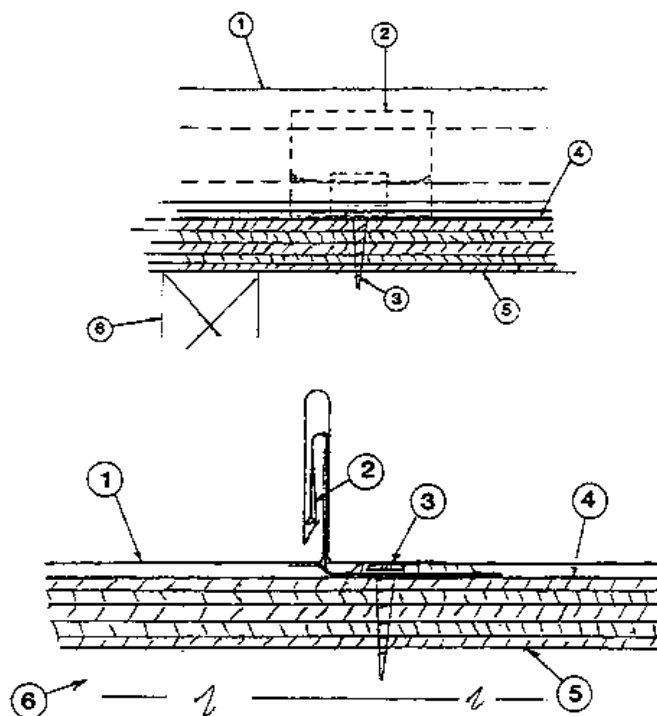

1. **Metal Roof Deck Panels*** — No. 24 MSG min coated steel panels, max 20 in. wide, min 9 in. wide, 1-1/2 in. high at female side rib. Panels continuous over three or more clips with no endlaps. A bead of sealant may be used at panel side joints.
 ATLANTA METAL PRODUCTS INC — "High Seam"
 CHARLESTON METALWORKS L L C — "1-1/2 in. Snap-Lok"
 CONSTRUCTION METAL PRODUCTS INC — "CMP Series 1000"
 NEW TECH MACHINERY CORP — "SS450"
 SPANN ROOFING & SHEET METAL INC — "Spann Series 1000"
 VINCENT METAL GOODS — "VMG System 2"
2. **Roof Deck Fasteners* (Panel Clips)** — One piece assembly, No. 24 MSG min coated steel, 1-3/4 in. wide, 1-1/4 in. high. Min thickness 0.025 in. (No. 24 MSG). Clips spaced 18 in. OC fastened to plywood deck.
 ATLANTA METAL PRODUCTS INC — "High Seam Roof Clip"
 ENGLERT INC — "Series 1000 Interlocking Clip"
3. **Fasteners (Screws)** — Fasteners used to attach panel clips (Item 2) to plywood to be No. 10-12 by 1 in. long pancake head, No. 2 Phillips drive, A-point, coated steel screw. Min one fastener per clip to be used.
4. **Underlayment** — Underlayment used over plywood deck to be type 30 organic felt. Sides overlapped min 2 in., end laps per manufacturer's instructions. Felt nailed to plywood deck with 1 in. long galv steel roofing nails, located per manufacturer's instructions. Nail spacing to be max 12 in. OC at the side lap and max 24 in. OC in interior rows.
5. **Plywood Decking** — Plywood decking to be graded per PS83 specifications, 19/32 in. thick min, exposure 1, APA rated, sq edged. Butt ends not blocked. All butt and side joints to be sealed with a one part urethane caulk sealant troweled smooth.
6. **Supports** — Spaced max of 24 in. OC. Any of the following types may be used to support the plywood decking:
 - a) 2 by 6 in. min, No. 2 grade or better A.F.P.A. S-P-F Hemlock Fir, Douglas Fir, Southern Pine or equivalent.
 - b) Wood trusses with a nom 2 by 4 in. upper chord of the same grade as Item a.
 - c) No. 22 MSG min cold formed coated steel (min yield to be 33,000 psi).
7. **Plywood Fasteners** — Fasteners used to attach the plywood deck to the supports to be as follows:
 - a) For plywood-to-wood supports No. 8-18 by 1-7/8 in. long bugle-head steel screws with a No. 2 Phillips drive, a "Hi-Low" thread pattern and an "S-Point."
 - b) For plywood-to-steel supports for a steel thickness less than No. 20 MSG, No. 7-19 by 1-1/4 in. long bugle-head steel screws with a No. 2 Phillips head drive "Hi-Low" threads and an "S-Point." For a steel thickness greater than No. 20 MSG to No. 16 MSG, No. 6-20 by 1-1/4 in. long bugle-head steel screws with a No. 2 Phillips drive and an 5/12 (TEKS/3)® point.
 Spacing: Fastener spacing for all fastener types to be 6 in. OC at the plywood butt edges and 12 in. OC in the interior. Refer to General Information, Roof Deck Construction (Roofing Materials & Systems Directory) for items not evaluated.

*Bearing the UL Classification Mark



Section Analysis Report

SS450 PANEL

PANEL ANALYSIS REPORT AND SPAN LOAD TABLES

Prepared For:
New Tech Machinery Corp.
1300 40th Street
Denver, CO 80205-3311

Prepared By:
John F. Butts & Associates, Inc.
2480 Vantage Drive
Colorado Springs, CO 80919

August 29, 2002
JOB NO. 183-05

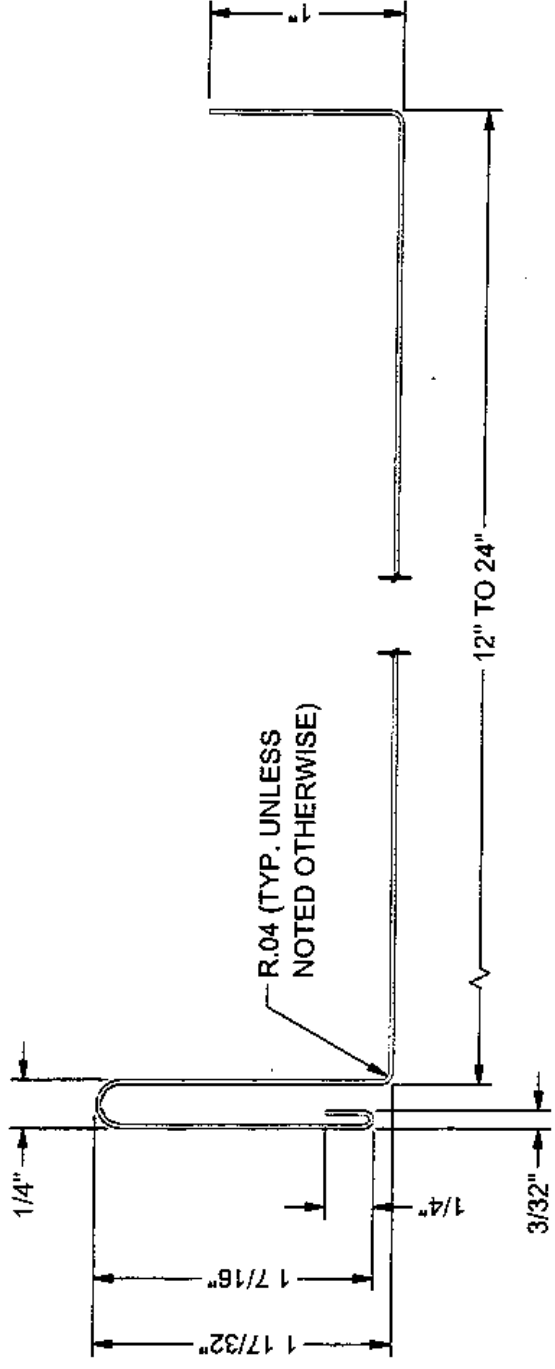
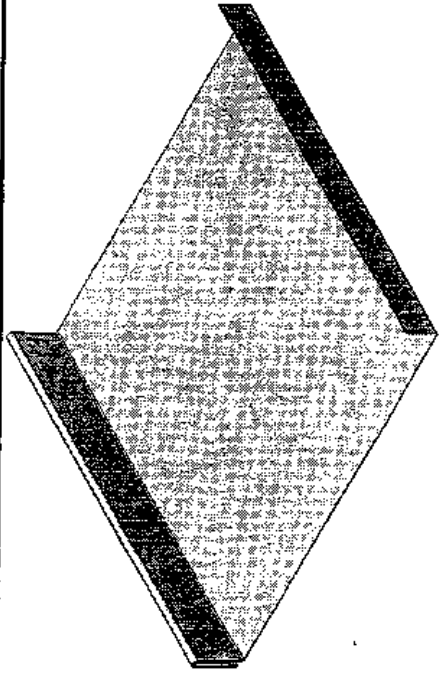

NOTE:
MATERIAL USAGE: 4"

REV		ECON NO.		DATE		RELEASED BY		TOLERANCES		DRAWN BY		PART NAME	
0				7/2/02				.XX = ± .01 .XXX = ± .005		SANDYER		NEW TECH MACHINERY CORP.	
REVISION HISTORY								FRACTION = ± 1/32"		CHECK BY		SS450 PANEL PROFILE	
								ANGLE = ± 1/2"		DATE		SIZE	
										7/2/2002		A	
										DATE		SCALE	
										DATE		FULL	
										DATE		PART NUMBER	
										DATE		SS450	
										DATE		REVISION	
										DATE		0	



JOHN F. BUTTS & ASSOC., INC.

CONSULTING ENGINEERS
2480 VANTAGE DRIVE COLORADO SPRINGS, CO 80919
(719) 598-7666 FAX (719) 598-0258
www.jfba.com

August 29, 2002

New Tech Machinery Corp.
1300 40th Street
Denver, CO 80205-3311

**Re: Section Analysis Report
New Tech SS450 Panel
Job No. 183-05**

Gentlemen:

Per your request, please find enclosed the engineering calculations for the above referenced project. The section, with the structural properties indicated in this report is certified to meet or exceed the requirements of the 1996 AISI Cold-Formed Steel Design Manual including Supplement No. 1 (July 1999).

Please note that the panel analysis and Load Tables have been evaluated based on the assumption that the proper bearing, side laps, end laps, bracing, anchorage and structural supports are being utilized in the member's installation. We do not certify the installation method, attachment and supporting materials.

If we can be of further assistance or if you require additional information, please call.

Sincerely,

John F. Butts, P.E.
President

enc. Section Drawing
Section Analysis
Section Load Tables



John F. Butts & Associates, Inc.
2480 Vantage Drive
Colorado Springs, CO 80919
(719) 598-7666

Analysis per 1996 AISI Cold-Formed Steel Manual + 1999 Supplement 1

New Tech SS450 Panel

FILE: SS450X12

SECTION DIMENSIONS

Line #1 Angle(L) =	-90.000 deg	Line #21 Angle(R) =	90.000 deg
Line #1 Radius(L) =	0.040 in	Line #21 Radius(R) =	0.040 in
Line #1 Length(L) =	0.000 in	Line #22 Length(R) =	1.336 in
Line #2 Angle(L) =	0.000 deg	Line #22 Angle(R) =	180.000 deg
Line #2 Radius(L) =	0.000 in	Line #22 Radius(R) =	0.100 in
Line #2 Length(L) =	0.936 in	Line #24 Length(R) =	1.254 in
Line #3 Angle(L) =	0.000 deg	Line #23 Angle(R) =	180.000 deg
Line #3 Radius(L) =	0.000 in	Line #23 Radius(R) =	0.025 in
Line #3 Length(L) =	0.000 in	Line #26 Length(R) =	0.201 in
Panel Bottom Width =	11.87 in		
Panel Overall Width =	12.00 in		
Panel Overall Height =	1.51 in		

Alloy: ASTM A792, G50

Fy = 50.00 ksi

Fv = 10.34 ksi

QUALIFICATIONS PER AISI SPECIFICATIONS

(a) Maximum w/t Ratio's Exceeded [Section B1.1(a)]: No

(b) Maximum h/t Ratio's Exceeded [Section B1.2(a)]: No

Section Dimensional Data

Type	Name	Gage	Height in	Width in	Lip in	t in	Weight plf	Coil Width in
Panel		24	1.512	12.000	0.000	0.024	1.325	16.230

Gross Sectional Properties

Area in ²	Ix in ⁴	Sx in ³	Rx in	Ycg in	Iy in ⁴	Sy in ³	Ry in	Xcg in
0.390	0.055	0.041	0.375	0.195	6.904	1.005	4.210	5.332

Effective Properties

Vnx kip	Ix in ⁴	Sx in ³	Mnx kip-in	Mny kip-in	Iy in ⁴	Sy in ³	Pne kip	Pnei kip/in
2.611	0.052	0.038	1.591	---	---	---	0.447	0.393

Torsional Properties

Xc in	Ro in	Beta	Cw in ⁶	Jv*1000 in ⁴	Fy ksi	Fu ksi	E ksi	G ksi
-0.548	4.262	0.983	1.613	0.075	50	65	29500	11300

Shear, moment and bearing values shown are nominal values and must be modified by the appropriate factors of safety (ASD) or resistance factors (LRFD).

Factors of Safety (ASD)		Resistance Factors (LRFD)	
FS (Compression)	= 1.80	RF (Compression)	= 0.85
FS (Tension)	= 1.67	RF (Tension)	= 0.95
FS (Web Crippling)	= 1.85	RF (Web Crippling)	= 0.75
FS (Bending)	= 1.67	RF (Bending)	= 0.90
FS (Shear)	= 1.67	RF (Shear)	= 0.90

Width | 12.00 in
 Alloy | ASTM A792, G50 (Fy =50 ksi)
 Gauge | 24 (0.024 in)

Allowable Strength Design (ASD)
 Wind Load Factor = 1.00
 Allowable Uniform Load (psf)

Span	Deflection	Span Length (Feet)								
		2.00	2.25	2.50	2.75	3.00	3.25	3.50	3.75	4.00
1	L/180	157	124	100	83	69	59	51	44	38
	L/240	157	124	100	83	69	59	51	44	38
	L/360	157	124	100	83	69	59	51	43	36
2	L/180	157	124	100	83	69	59	51	44	38
	L/240	157	124	100	83	69	59	51	44	38
	L/360	157	124	100	83	69	59	51	44	38
3	L/180	181	143	116	96	80	68	59	51	45
	L/240	181	143	116	96	80	68	59	51	45
	L/360	181	143	116	96	80	68	59	51	45

- Formula's used in Load Tables for FLEXURE and DEFLECTION are:
 One Span - $M_p = .125wl^2$, $M_n = .125wl^2$, $x = .0130wl^4/EI$
 Two Span - $M_p = .125wl^2$, $M_n = .096wl^2$, $x = .0092wl^4/EI$
 Three Span - $M_p = .080wl^2$, $M_n = .107wl^2$, $x = .0069wl^4/EI$
 Modulus of Elasticity (E) = 29500 ksi
- Allowable uniform loads are determined per the following:
 a) Allowable Shear Stress (Fv) [AISI, C3.2]
 b) Combined Bending and Shear [AISI, C3.3]
 c) Combined Bending & Web Crippling [AISI C3.5]
- Factors of Safety used to determine uniform loads:
 FS (Bending) = 1.67
 FS (Shear) = 1.67
 FS (Web Crippling) = 1.85
- Allowance has been made for member Dead Weight.
- Minimum panel support bearing length = 2.00 in
- Concentrated load = 250 lbs at mid-span, load width = 4 in
 Simple Span : Maximum Span = 2.024 ft (L/180)
 Two Span : Maximum Span = 2.375 ft (L/180)
 Three Span + : Maximum Span = 2.531 ft (L/180)

Width | 12.00 in
 Alloy | ASTM A792, G50 (Fy =50 ksi)
 Gauge | 24 (0.024 in)

Allowable Strength Design (ASD)
 Wind Load Factor = 1.00
 Allowable Uniform Load (psf)

Span	Deflection	Span Length (Feet)								
		4.25	4.50	4.75	5.00	5.25	5.50	5.75	6.00	6.25
1	L/180	34	30	27	24	22	20	18	16	15
	L/240	34	30	27	24	22	20	18	16	14
	L/360	30	25	21	18	16	14	12	11	9
2	L/180	34	30	27	24	22	20	18	16	15
	L/240	34	30	27	24	22	20	18	16	15
	L/360	34	30	27	24	22	19	17	15	13
3	L/180	40	35	31	28	26	23	21	19	18
	L/240	40	35	31	28	26	23	21	19	18
	L/360	40	35	31	28	26	23	21	19	18

- Formula's used in Load Tables for FLEXURE and DEFLECTION are:
 One Span - $M_p = .125wl^2$, $M_n = .125wl^2$, $x = .0130wl^4/EI$
 Two Span - $M_p = .125wl^2$, $M_n = .096wl^2$, $x = .0092wl^4/EI$
 Three Span - $M_p = .080wl^2$, $M_n = .107wl^2$, $x = .0069wl^4/EI$
 Modulus of Elasticity (E) = 29500 ksi
- Allowable uniform loads are determined per the following:
 a) Allowable Shear Stress (Fv) [AISI, C3.2]
 b) Combined Bending and Shear [AISI, C3.3]
 c) Combined Bending & Web Crippling [AISI C3.5]
- Factors of Safety used to determine uniform loads:
 FS (Bending) = 1.67
 FS (Shear) = 1.67
 FS (Web Crippling) = 1.85
- Allowance has been made for member Dead Weight.
- Minimum panel support bearing length = 2.00 in
- Concentrated load = 250 lbs at mid-span, load width = 4 in
 Simple Span : Maximum Span = 2.024 ft (L/180)
 Two Span : Maximum Span = 2.375 ft (L/180)
 Three Span + : Maximum Span = 2.531 ft (L/180)

John F. Butts & Associates, Inc.
2480 Vantage Drive
Colorado Springs, CO 80919
(719) 598-7666

Analysis per 1996 AISI Cold-Formed Steel Manual + 1999 Supplement 1

New Tech SS450 Panel

FILE: SS450X16

SECTION DIMENSIONS

Line #1 Angle(L) =	-90.000 deg	Line #21 Angle(R) =	90.000 deg
Line #1 Radius(L) =	0.040 in	Line #21 Radius(R) =	0.040 in
Line #1 Length(L) =	0.000 in	Line #22 Length(R) =	1.336 in
Line #2 Angle(L) =	0.000 deg	Line #22 Angle(R) =	180.000 deg
Line #2 Radius(L) =	0.000 in	Line #22 Radius(R) =	0.100 in
Line #2 Length(L) =	0.936 in	Line #24 Length(R) =	1.254 in
Line #3 Angle(L) =	0.000 deg	Line #23 Angle(R) =	180.000 deg
Line #3 Radius(L) =	0.000 in	Line #23 Radius(R) =	0.025 in
Line #3 Length(L) =	0.000 in	Line #26 Length(R) =	0.201 in
Panel Bottom Width =	15.87 in		
Panel Overall Width =	16.00 in		
Panel Overall Height =	1.51 in		

Alloy: ASTM A792, G50
Fy = 50.00 ksi
Fv = 7.41 ksi

QUALIFICATIONS PER AISI SPECIFICATIONS

- (a) Maximum w/t Ratio's Exceeded [Section B1.1(a)]: No
- (b) Maximum h/t Ratio's Exceeded [Section B1.2(a)]: No

Section Dimensional Data

Type	Name	Gage	Height in	Width in	Lip in	t in	Weight plf	Coil Width in
Panel		24	1.512	16.000	0.000	0.024	1.652	20.230

Gross Sectional Properties

Area in ²	Ix in ⁴	Sx in ³	Rx in	Ycg in	Iy in ⁴	Sy in ³	Ry in	Xcg in
0.486	0.057	0.042	0.343	0.159	14.390	1.613	5.444	7.276

Effective Properties

Vnx kip	Ix in ⁴	Sx in ³	Mnx kip-in	Mny kip-in	Iy in ⁴	Sy in ³	Pne kip	Pnei kip/in
2.611	0.054	0.038	1.593	--	--	--	0.447	0.393

Torsional Properties

Xo in	Ro in	Beta	Cw in ⁶	Jv*1000 in ⁴	Fy ksi	Fu ksi	E ksi	G ksi
-0.455	5.474	0.993	3.086	0.093	50	65	29500	11300

Shear, moment and bearing values shown are nominal values and must be modified by the appropriate factors of safety (ASD) or resistance factors (LRFD).

Factors of Safety (ASD)		Resistance Factors (LRFD)	
FS (Compression)	= 1.80	RF (Compression)	= 0.85
FS (Tension)	= 1.67	RF (Tension)	= 0.95
FS (Web Crippling)	= 1.85	RF (Web Crippling)	= 0.75
FS (Bending)	= 1.67	RF (Bending)	= 0.90
FS (Shear)	= 1.67	RF (Shear)	= 0.90

Width | 16.00 in
 Alloy | ASTM A792, G50 (Fy =50 ksi)
 Gauge | 24 (0.024 in)

Allowable Strength Design (ASD)
 Wind Load Factor = 1.00
 Allowable Uniform Load (psf)

Span	Deflection	Span Length (Feet)								
		2.00	2.25	2.50	2.75	3.00	3.25	3.50	3.75	4.00
1	L/180	118	93	75	62	52	44	38	33	29
	L/240	118	93	75	62	52	44	38	33	29
	L/360	118	93	75	62	52	44	38	33	28
2	L/180	118	93	75	62	52	44	38	33	29
	L/240	118	93	75	62	52	44	38	33	29
	L/360	118	93	75	62	52	44	38	33	29
3	L/180	136	107	87	72	60	51	44	38	33
	L/240	136	107	87	72	60	51	44	38	33
	L/360	136	107	87	72	60	51	44	38	33

- Formula's used in Load Tables for FLEXURE and DEFLECTION are:
 One Span - $M_p = .125wl^2$, $M_n = .125wl^2$, $x = .0130wl^4/EI$
 Two Span - $M_p = .125wl^2$, $M_n = .096wl^2$, $x = .0092wl^4/EI$
 Three Span - $M_p = .080wl^2$, $M_n = .107wl^2$, $x = .0069wl^4/EI$
 Modulus of Elasticity (E) = 29500 ksi
- Allowable uniform loads are determined per the following:
 a) Allowable Shear Stress (Fv) [AISI, C3.2]
 b) Combined Bending and Shear [AISI, C3.3]
 c) Combined Bending & Web Crippling [AISI C3.5]
- Factors of Safety used to determine uniform loads:
 FS (Bending) = 1.67
 FS (Shear) = 1.67
 FS (Web Crippling) = 1.85
- Allowance has been made for member Dead Weight.
- Minimum panel support bearing length = 2.00 in
- Concentrated load = 250 lbs at mid-span, load width = 4 in
 Simple Span : Maximum Span = 1.999 ft (L/180)
 Two Span : Maximum Span = 2.344 ft (L/180)
 Three Span + : Maximum Span = 2.498 ft (L/180)

Width | 16.00 in
 Alloy | ASTM A792, G50 (Fy =50 ksi)
 Gauge | 24 (0.024 in)

Allowable Strength Design (ASD)
 Wind Load Factor = 1.00
 Allowable Uniform Load (psf)

Span	Deflection	Span Length (Feet)								
		4.25	4.50	4.75	5.00	5.25	5.50	5.75	6.00	6.25
1	L/180	25	22	20	18	16	15	13	12	11
	L/240	25	22	20	18	16	15	13	12	11
	L/360	23	19	17	14	12	11	9	8	7
2	L/180	25	22	20	18	16	15	13	12	11
	L/240	25	22	20	18	16	15	13	12	11
	L/360	25	22	20	18	16	15	13	12	10
3	L/180	29	26	23	21	19	17	16	14	13
	L/240	29	26	23	21	19	17	16	14	13
	L/360	29	26	23	21	19	17	16	14	13

- Formula's used in Load Tables for FLEXURE and DEFLECTION are:
 One Span - $M_p = .125wl^2$, $M_n = .125wl^2$, $x = .0130wl^4/EI$
 Two Span - $M_p = .125wl^2$, $M_n = .096wl^2$, $x = .0092wl^4/EI$
 Three Span - $M_p = .080wl^2$, $M_n = .107wl^2$, $x = .0069wl^4/EI$
 Modulus of Elasticity (E) = 29500 ksi
- Allowable uniform loads are determined per the following:
 a) Allowable Shear Stress (Fv) [AISI, C3.2]
 b) Combined Bending and Shear [AISI, C3.3]
 c) Combined Bending & Web Crippling [AISI C3.5]
- Factors of Safety used to determine uniform loads:
 FS (Bending) = 1.67
 FS (Shear) = 1.67
 FS (Web Crippling) = 1.85
- Allowance has been made for member Dead Weight.
- Minimum panel support bearing length = 2.00 in
- Concentrated load = 250 lbs at mid-span, load width = 4 in
 Simple Span : Maximum Span = 1.999 ft (L/180)
 Two Span : Maximum Span = 2.344 ft (L/180)
 Three Span + : Maximum Span = 2.498 ft (L/180)

John F. Butts & Associates, Inc.
2480 Vantage Drive
Colorado Springs, CO 80919
(719) 598-7666

Analysis per 1996 AISI Cold-Formed Steel Manual + 1999 Supplement I

New Tech SS450 Panel

FILE: SS450X18

SECTION DIMENSIONS

Line #1 Angle(L) =	-90.000 deg	Line #21 Angle(R) =	90.000 deg
Line #1 Radius(L) =	0.040 in	Line #21 Radius(R) =	0.040 in
Line #1 Length(L) =	0.000 in	Line #22 Length(R) =	1.336 in
Line #2 Angle(L) =	0.000 deg	Line #22 Angle(R) =	180.000 deg
Line #2 Radius(L) =	0.000 in	Line #22 Radius(R) =	0.100 in
Line #2 Length(L) =	0.936 in	Line #24 Length(R) =	1.254 in
Line #3 Angle(L) =	0.000 deg	Line #23 Angle(R) =	180.000 deg
Line #3 Radius(L) =	0.000 in	Line #23 Radius(R) =	0.025 in
Line #3 Length(L) =	0.000 in	Line #26 Length(R) =	0.201 in

Panel Bottom Width	=	17.87 in
Panel Overall Width	=	18.00 in
Panel Overall Height	=	1.51 in

Alloy: ASTM A792, G50

Fy = 50.00 ksi

Fv = 7.17 ksi

QUALIFICATIONS PER AISI SPECIFICATIONS

- (a) Maximum w/t Ratio's Exceeded [Section B1.1(a)]: No
- (b) Maximum h/t Ratio's Exceeded [Section B1.2(a)]: No

Section Dimensional Data

Type	Name	Gage	Height in	Width in	Lip in	t in	Weight plf	Coil Width in
Panel		24	1.512	18.000	0.000	0.024	1.815	22.230

Gross Sectional Properties

Area in ²	Ix in ⁴	Sx in ³	Rx in	Ycg in	Iy in ⁴	Sy in ³	Ry in	Xcg in
0.534	0.058	0.043	0.330	0.145	19.541	1.965	6.052	8.256

Effective Properties

Vnx kip	Ix in ⁴	Sx in ³	Mnx kip-in	Mny kip-in	Iy in ⁴	Sy in ³	Pne kip	Pnei kip/in
2.611	0.055	0.037	1.594	---	---	---	0.447	0.393

Torsional Properties

Xo in	Ro in	Beta	Cw in ⁶	Jv*1000 in ⁴	Fy ksi	Fu ksi	E ksi	G ksi
-0.419	6.075	0.995	4.015	0.102	50	65	29500	11300

Shear, moment and bearing values shown are nominal values and must be modified by the appropriate factors of safety (ASD) or resistance factors (LRFD).

Factors of Safety (ASD)		Resistance Factors (LRFD)	
FS (Compression)	= 1.80	RF (Compression)	= 0.85
FS (Tension)	= 1.67	RF (Tension)	= 0.95
FS (Web Crippling)	= 1.85	RF (Web Crippling)	= 0.75
FS (Bending)	= 1.67	RF (Bending)	= 0.90
FS (Shear)	= 1.67	RF (Shear)	= 0.90

Width | 18.00 in
 Alloy | ASTM A792, G50 (Fy =50 ksi)
 Gauge | 24 (0.024 in)

Allowable Strength Design (ASD)
 Wind Load Factor = 1.00
 Allowable Uniform Load (psf)

Span	Deflection	Span Length (Feet)								
		2.00	2.25	2.50	2.75	3.00	3.25	3.50	3.75	4.00
1	L/180	105	83	67	55	46	39	33	29	25
	L/240	105	83	67	55	46	39	33	29	25
	L/360	105	83	67	55	46	39	33	29	25
2	L/180	105	83	67	55	46	39	33	29	25
	L/240	105	83	67	55	46	39	33	29	25
	L/360	105	83	67	55	46	39	33	29	25
3	L/180	121	95	77	64	53	45	39	34	30
	L/240	121	95	77	64	53	45	39	34	30
	L/360	121	95	77	64	53	45	39	34	30

1. Formula's used in Load Tables for FLEXURE and DEFLECTION are:

One Span - $M_p = .125wl^2$, $M_n = .125wl^2$, $x = .0130wl^4/EI$
 Two Span - $M_p = .125wl^2$, $M_n = .096wl^2$, $x = .0092wl^4/EI$
 Three Span - $M_p = .080wl^2$, $M_n = .107wl^2$, $x = .0069wl^4/EI$
 Modulus of Elasticity (E) = 29500 ksi

2. Allowable uniform loads are determined per the following:

- a) Allowable Shear Stress (Fv) [AISI, C3.2]
- b) Combined Bending and Shear [AISI, C3.3]
- c) Combined Bending & Web Crippling [AISI C3.5]

3. Factors of Safety used to determine uniform loads:

FS (Bending) = 1.67
 FS (Shear) = 1.67
 FS (Web Crippling) = 1.85

4. Allowance has been made for member Dead Weight.

5. Minimum panel support bearing length = 2.00 in

6. Concentrated load = 250 lbs at mid-span, load width = 4 in

Simple Span : Maximum Span = 1.989 ft (L/180)
 Two Span : Maximum Span = 2.332 ft (L/180)
 Three Span + : Maximum Span = 2.485 ft (L/180)

Width | 18.00 in
 Alloy | ASTM A792, G50 (Fy =50 ksi)
 Gauge | 24 (0.024 in)

Allowable Strength Design (ASD)
 Wind Load Factor = 1.00
 Allowable Uniform Load (psf)

Span	Deflection	Span Length (Feet)								
		4.25	4.50	4.75	5.00	5.25	5.50	5.75	6.00	6.25
1	L/180	22	20	18	16	14	13	12	11	10
	L/240	22	20	18	16	14	13	12	11	10
	L/360	21	18	15	13	11	10	8	7	7
2	L/180	22	20	18	16	14	13	12	11	10
	L/240	22	20	18	16	14	13	12	11	10
	L/360	22	20	18	16	14	13	12	10	9
3	L/180	26	23	21	19	17	15	14	13	11
	L/240	26	23	21	19	17	15	14	13	11
	L/360	26	23	21	19	17	15	14	13	11

1. Formula's used in Load Tables for FLEXURE and DEFLECTION are:

One Span - $M_p = .125wl^2$, $M_n = .125wl^2$, $x = .0130wl^4/EI$
 Two Span - $M_p = .125wl^2$, $M_n = .096wl^2$, $x = .0092wl^4/EI$
 Three Span - $M_p = .080wl^2$, $M_n = .107wl^2$, $x = .0069wl^4/EI$
 Modulus of Elasticity (E) = 29500 ksi

2. Allowable uniform loads are determined per the following:

- a) Allowable Shear Stress (Fv) [AISI, C3.2]
- b) Combined Bending and Shear [AISI, C3.3]
- c) Combined Bending & Web Crippling [AISI C3.5]

3. Factors of Safety used to determine uniform loads:

FS (Bending) = 1.67
 FS (Shear) = 1.67
 FS (Web Crippling) = 1.85

4. Allowance has been made for member Dead Weight.

5. Minimum panel support bearing length = 2.00 in

6. Concentrated load = 250 lbs at mid-span, load width = 4 in

Simple Span : Maximum Span = 1.989 ft (L/180)
 Two Span : Maximum Span = 2.332 ft (L/180)
 Three Span + : Maximum Span = 2.485 ft (L/180)

